

EP7013C Single Output Integrated Voltage Regulator IC

Features

- Step-down Integrated Voltage Regulator (IVR): 3A
- No discrete inductors or capacitors required
- Industry's highest current density: 0.4A / mm²
- Programmable output voltage: 0.40V to 1.31V
- Output voltage set point accuracy: $\pm 1.0\%$ over PVT
- Ultra-fast transient response with no output caps
- Programmable fast DVS: up to 12 mV/ns
- Programmable auto-phase shedding
- High efficiency and wide bandwidth
- Extensive fault protection, programming and warning: OVLO, UVLO, OVP, OCP, short-circuit
- Accurate current ($\pm 10\%$), voltage ($\pm 2\%$), and temperature reporting ($\pm 4^\circ\text{C}$)
- Adjustable, fast soft-start with low in-rush current
- Programmable power-up sequencing
- VR synchronization to external clock
- 28MHz I3C interface to coordinate sequencing, telemetry and diagnostics with system and SoC

Applications

- Server POL
- Optical transceiver SoCs & Modules
- Client/Enterprise/Data Center SSD & NAS
- Networking & Communication SoCs
- Artificial Intelligence (AI) Processors

Description

The EP7013 is a high-performance highly Integrated Voltage Regulator (IVR) with an output of 3A that enables the full integration or elimination of all external components. Operating from a 1.8V input supply, or as the 2nd stage of 2-stage conversion, the EP7013 offers the industry best density, efficiency, transient performance and dynamic voltage scaling (DVS) from any system input voltage.

The output is capable of 0.4V to 1.31V at 3A each to provide flat efficiency curves and ultra-wide bandwidth. The EP7013 offers extensive independent programmability with no external discrete components required. Highly accurate telemetry, diagnostics, warnings and protection as well as operating parameters such as output voltage, soft-start time and sequencing, DVS ramp speed, and phase shedding are all programmable via the I3C interface. The EP7013 reduces PCB power management area and components by 10x or more, reduces system power loss by 10-50%, and reduces power routing complexity on the PCB.

Offered in a 5mm x 5mm x 0.74mm or 4.15mm x 4.15mm x 0.75mm FcCSP package, the EP7013C is perfect for space constrained and thin profile applications. Die form is available.

Typical Application

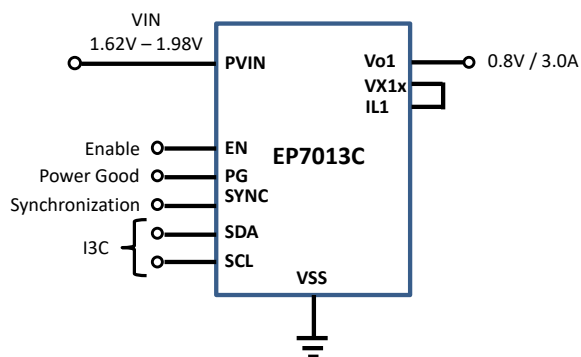



Data Sheet Notice & Legal Disclaimer

ADVANCE INFORMATION (engineering prototypes, meaning limited sample availability) or PRELIMINARY INFORMATION (preproduction or first production) are used to advise customers of additions to the product line that, nevertheless, still have “preproduction” status. Details may, therefore, change without notice although it is expected that preliminary performance data is representative of “full production” status. Contact your local sales office for details of current status and latest specifications.

Empower Semiconductor
1164 Cadillac Ct.
Milpitas, CA 95035

© 2020 Empower Semiconductor, Inc. All rights reserved.

Empower products are sold by description only. Empower Semiconductor, Inc. reserves the right to make changes in circuit design, software and/or specifications at any time without notice. Accordingly, the reader is cautioned to verify that data sheets are current before placing orders. Information furnished by Empower is believed to be accurate and reliable. However, no responsibility is assumed by Empower or its subsidiaries for its use; nor for any infringements of patents or other rights of third parties which may result from its use. No license is granted by implication or otherwise under any patent or patent rights of Empower or its subsidiaries.

For information regarding Empower Semiconductor, Inc. and its products, visit www.empowersemi.com