

Features

- Three Integrated Voltage Regulators (IVR): 4A, 2A, & 4A
- No discrete inductors or capacitors required
- PCB usage limited to outer layer through interposer
- Industry's highest current density: 0.125A / mm²
- Programmable output voltage: 0.50V to 1.20V
- Output voltage set point accuracy: $\pm 1.0\%$ over PVT
- Ultra-fast transient response with no output caps
- Programmable fast DVS: up to 6 mV/ns
- Programmable auto-phase shedding
- High efficiency and wide bandwidth
- Extensive fault protection, programming and warning: OVLO, UVLO, OVP, OCP, short-circuit
- Accurate current ($\pm 10\%$), voltage ($\pm 2\%$), and temperature reporting ($\pm 4^\circ\text{C}$)
- Adjustable, fast soft-start with low in-rush current
- Programmable power-up sequencing
- 28MHz I3C interface (compatible to I2C) to coordinate sequencing, telemetry and diagnostics with system and SoC

Applications

- Server POL
- Optical transceiver SoCs & Modules
- Client/Enterprise/Data Center SSD & NAS
- Networking & Communication SoCs
- Artificial Intelligence (AI) Processors

Description

The EP7038 is a high-performance highly Integrated Voltage Regulator (IVR) with three outputs totaling 10A that enables the full integration of multiple voltage rails all in one IC, eliminating all external components. Operating from a 1.8V input supply, the EP7038 offers the industry best density, efficiency, transient performance and dynamic voltage scaling (DVS) from any system input voltage.

The three outputs are capable of 0.5V to 1.20V with 4A, 2A, and 4A respectively to provide flat efficiency curves and ultra-wide bandwidth. The EP7038 offers extensive independent programmability for each of its three outputs, requiring no external discrete components. Highly accurate telemetry, diagnostics, warnings and protection as well as operating parameters such as output voltage, soft-start time and sequencing, DVS ramp speed, and phase shedding are all programmable via the I3C interface. The EP7038 reduces PCB power management area and components by 10x or more, reduces system power loss by 10-50%, and reduces power routing complexity on the PCB.

Offered in an 8mm x 10mm x 2.45mm LGA package, the EP7038B is perfect for space constrained and thin profile applications that are challenged by complexity. The interposer comprises the FcCSP IVR and all associated PCB design, therefore eliminating the need to use any inner layers on a system PCB, enabling the least complex designs.

Typical Application

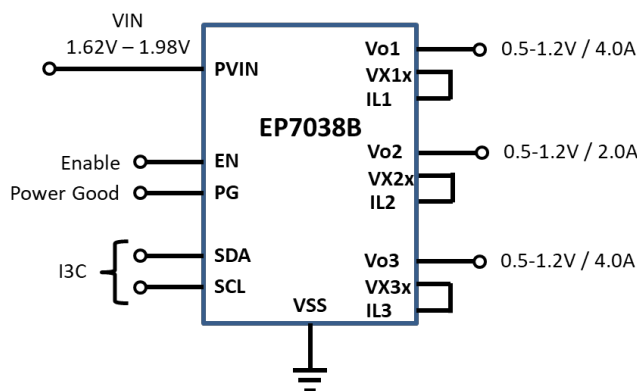

Package Outline Drawing

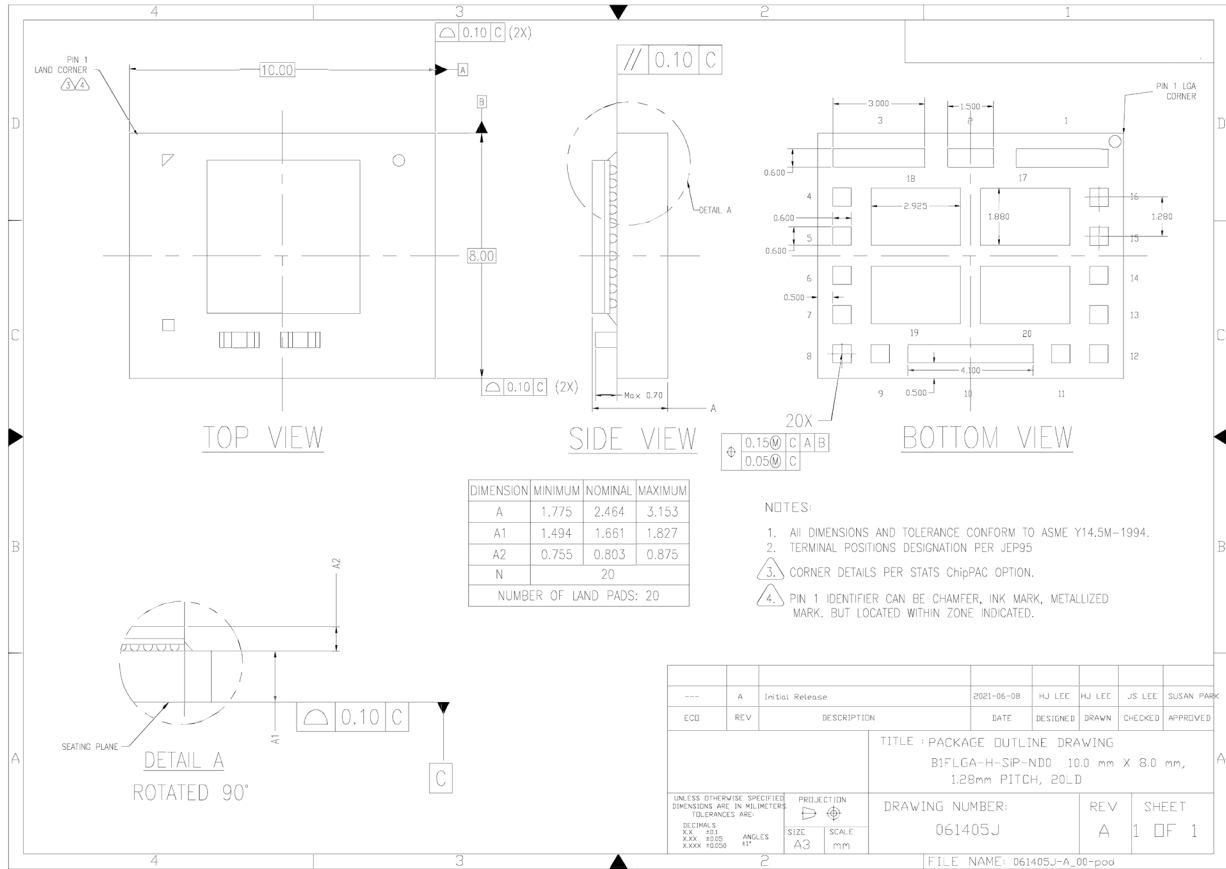

Data Sheet Notice & Legal Disclaimer

ADVANCE INFORMATION (engineering prototypes, meaning limited sample availability) or PRELIMINARY INFORMATION (preproduction or first production) are used to advise customers of additions to the product line that, nevertheless, still have “preproduction” status. Details may, therefore, change without notice although it is expected that preliminary performance data is representative of “full production” status. Contact your local sales office for details of current status and latest specifications.

Empower Semiconductor
1164 Cadillac Ct.
Milpitas, CA 95035

© 2021 Empower Semiconductor, Inc. All rights reserved.

Empower products are sold by description only. Empower Semiconductor, Inc. reserves the right to make changes in circuit design, software and/or specifications at any time without notice. Accordingly, the reader is cautioned to verify that data sheets are current before placing orders. Information furnished by Empower is believed to be accurate and reliable. However, no responsibility is assumed by Empower or its subsidiaries for its use; nor for any infringements of patents or other rights of third parties which may result from its use. No license is granted by implication or otherwise under any patent or patent rights of Empower or its subsidiaries.

For information regarding Empower Semiconductor, Inc. and its products, visit www.empowersemi.com