

Powering the AI Revolution

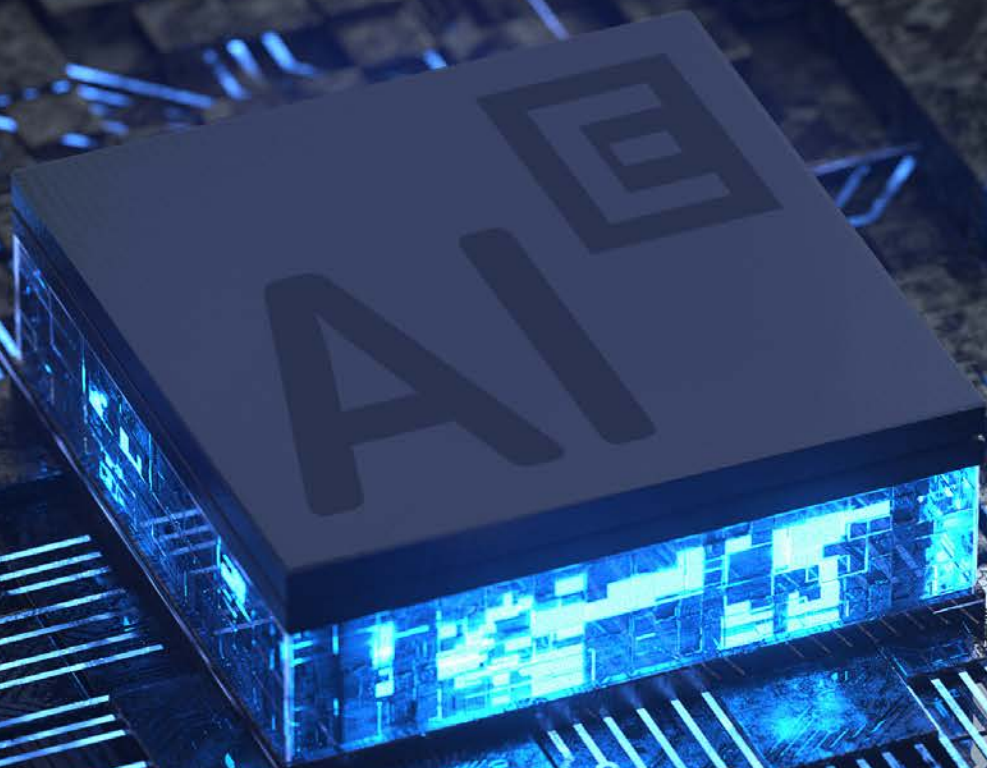

EMPOWER
SEMICONDUCTOR

Power Management Solutions for kilowatt-class AI, HPC, xPU Processors

- Powering the AI revolution
- kilowatt-class vertical power delivery
- Chiplet and System Power Integrated Voltage Regulators (IVR)
- Ultimate power and signal integrity Silicon Capacitors
 - Ultra-low ESL for high frequency decoupling
- FinFast™ powered industry's most compact and fastest step-down converters
- World class wafer foundry, assembly and test
- Headquartered in Milpitas, California, USA
- Worldwide Sales Representatives and Distributors

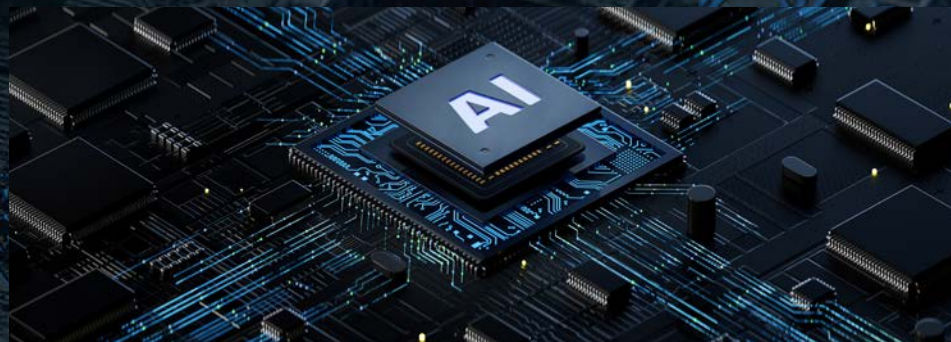

kilowatt-class AI - HPC - xPU Power

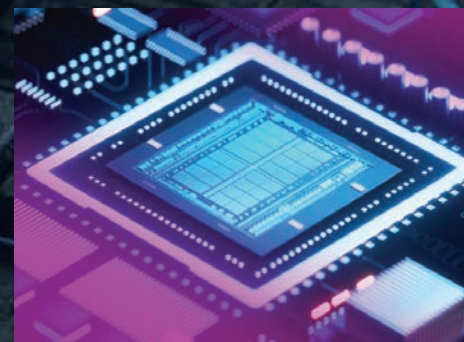

Chiplet & System Power



Data Centers



Networking

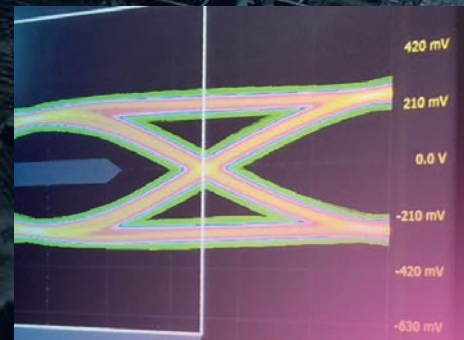

Power Integrity

kilowatt-class Vertical Power Delivery

Crescendo

2.6kA+ Scalable On-demand Vertical Power Delivery Platform

Key Benefits

- Scalable to **2,600A** peak current
 - 65A output current per power leaf
 - **-1°C/W** thermal performance
 - Meets AI/HPC xPU power demands
- True **vertical power** delivery
 - Ultra-wide bandwidth, fast transient response
 - Eliminates decoupling capacitor bank
 - 5x higher total solution density (A/mm²)
- Integrated inductor and input capacitors
- 2.2 mm ultra-low profile package
 - Backside cooling compatible
- 6 x 7 mm thermally enhanced package
 - EP9501 Supervisor
 - 6x6 mm 40-pin QFN package
- Minimize energy footprint
 - Eliminates lateral power delivery losses
 - >90% efficiency, vertical current flow
 - Reduced voltage margining

Industry Standard Interfaces

- PMBus and AVSBus
- Telemetry and remote diagnostics
 - Current, voltage and temperature
- Complete fault protection and warnings
 - Temperature, input/output voltage and short circuit protections
- Configurable multi-function GPIOs

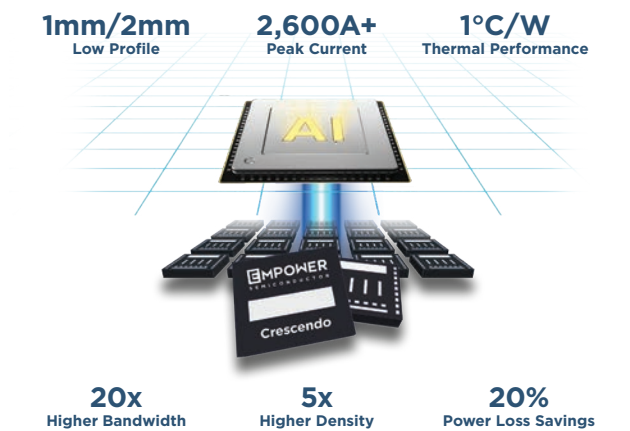

EP7502 vs Traditional VR: Load Transient 5A to 500A in 450ns

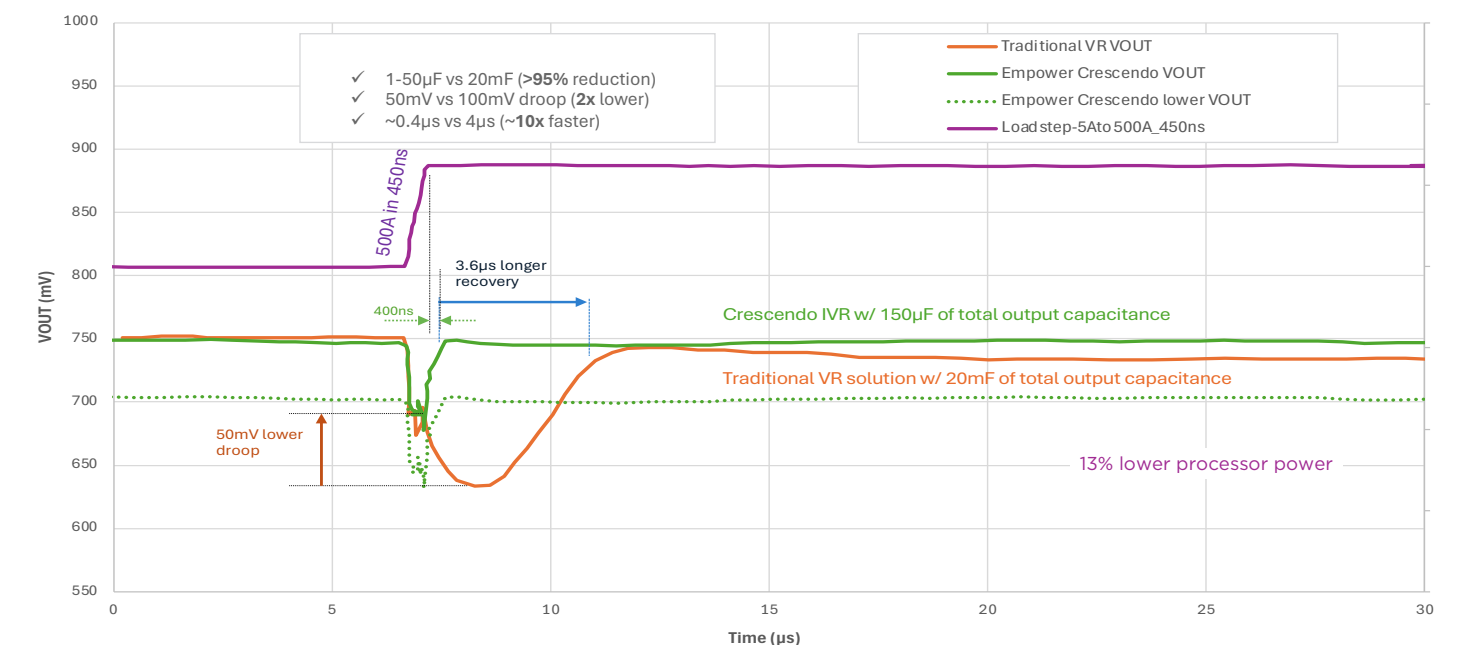

Chiplet & System Power Integrated Voltage Regulators (IVR)

Power Integrity – Silicon Capacitors

EP71xx IVR Series

Industry's Smallest and Fastest Integrated Voltage Regulator

- 12A/25W total current/power
- 1-4 outputs
- 3.3V_{IN}
- I2C interface
- Flexible sequencing
- Multi-time programming
- 5 x 7 x 0.7 mm package

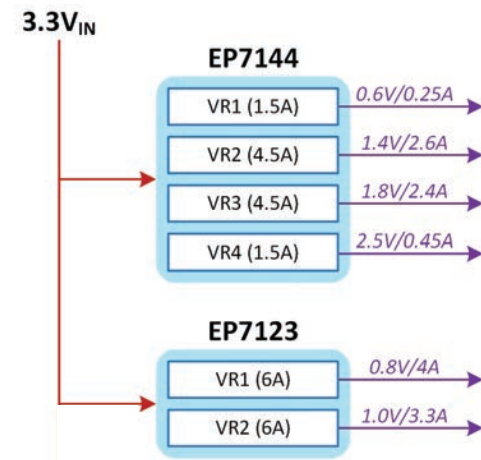

Empower patented IVR technology eliminates dozens of discrete components. The result is power delivery with unprecedented simplicity, speed, accuracy, and no discrete components.

Flexible Design Options

Smallest BOM and Footprint



EP71xx + PCB Inductors

- <5 components BOM
- 35-40 mm² top side area
- 0.75 mm solution height

Highest Efficiency



EP71xx with Magnetic Inductors

- <5 components BOM
- 35-40 mm² top side area
- 0.75 mm solution height

EP70xx IVR Series

Seamless Integration into Chiplet-based and SoC systems

- 10A (package)/10A (die) total current
- 1-3 outputs
- 1.8VIN
- I2C interface
- 5 x 5 x 0.8 mm package
- 6.7mm² die form

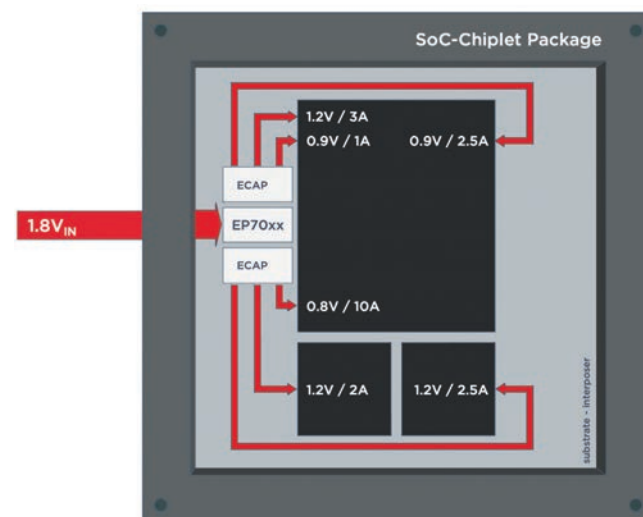

ECAPs

Enabling new levels of Power and Signal Integrity

- Deep trench capacitor technology
- Single or multi-domains capacitors
- Ultra-low ESL
 - Less than 5pH
- Ultra-low ESR
- Wide bandwidth 10MHz-10GHz
- High capacitance density form factor
- Ultra-thin profile: down to 50µm
 - Custom profile available
- Substrate embedding
- Die/land side mounting
- Stability and reliability
 - No DC or AC derating
 - No aging or temperature derating
- Standard & custom solutions

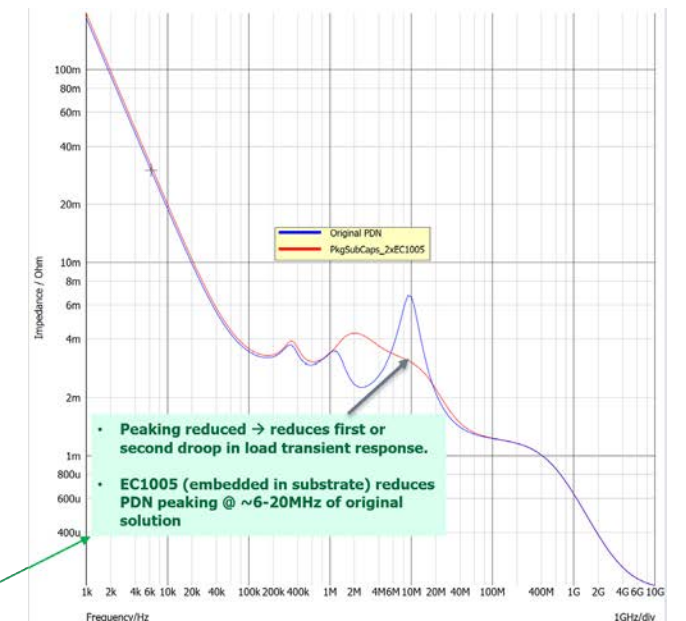
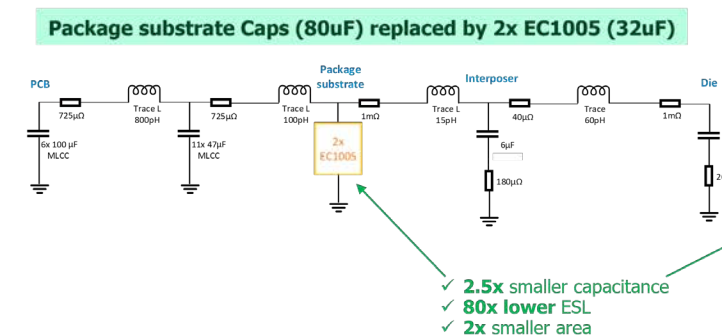
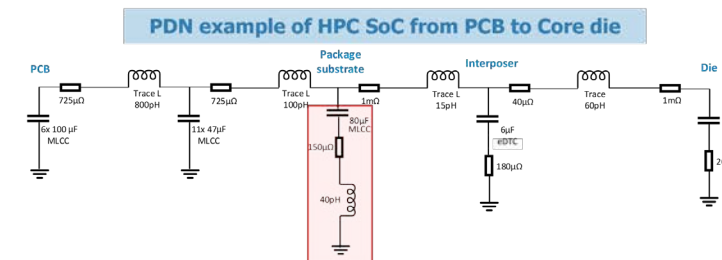
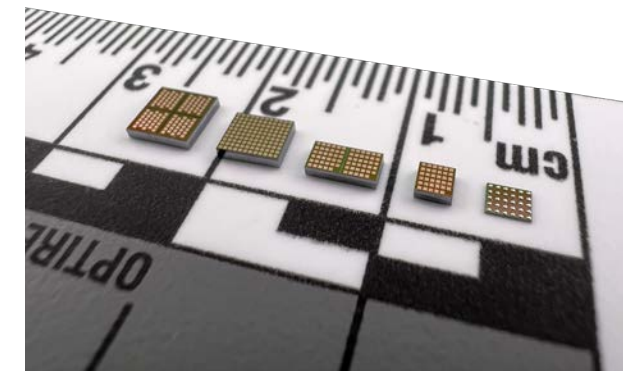
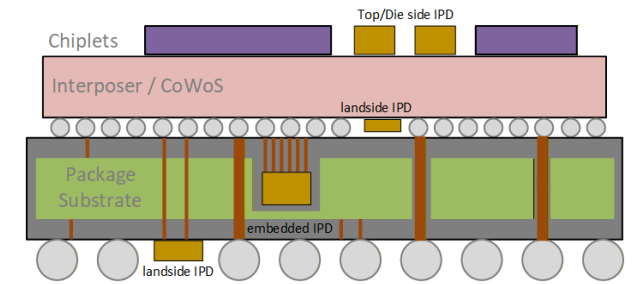

The FinFast™ technology operates with benchmark efficiency at blazing speeds utilizing cutting-edge silicon combined with novel control architectures, high-frequency magnetics, wide-bandwidth capacitors and best-in-class power packaging.

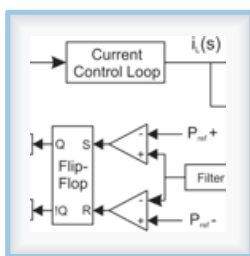

Innovative Architectures

- Very high frequency and low noise
- 1,000x faster power delivery
- High digital content for configurability

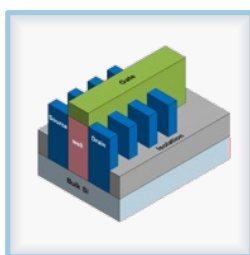

FinFast™ Power Design

- FinFET cells as power devices
- High current voltage stacking
- High speed efficient switching

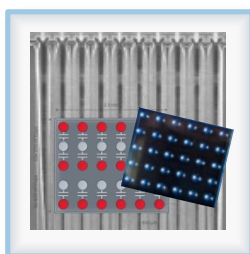

Silicon Capacitors

- Industry's most dense capacitance
- Low ESL/ESR power delivery network
- Land side, die side and embedding

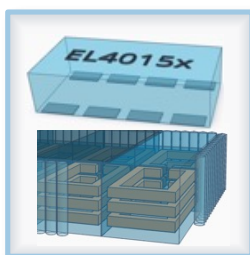

Advanced Magnetics

- High frequency magnetic material
- Proprietary design/IP
- Air core design experts



Advanced Power Packaging

- Custom power packages
- High-frequency and power optimized
- As low as $-1^{\circ}\text{C}/\text{W}$ dual side cooling

kilowatt-class Vertical Power Delivery

Part Number		Max Current	Bandwidth	VIN	Package Size	Height	
EP7502MC	Power Leaf	65A	Fast	3.3V	6 x 7 mm	2.2 mm	w/ thermal slug
EP9501	Controller				6 x 6 mm	0.7 mm	

IVR - Chiplet & System Power Regulators

Part Number	Outputs	Output 1	Output 2	Output 3	Output 4	VIN	Package Size	Solution Size	Optimized for
EP7112C	1	12A				3.3V	5 x 7 mm	35 mm ²	System Power
EP7124C	2	10.5A	1.5A						
EP7122C		9A	3A						
EP7125C		7.5A	4.5A						
EP7123C		6A	6A						
EP7139C	3	9A	1.5A	1.5A					
EP7131C		6A	4.5A	1.5A					
EP7136C		6A	3A	3A					
EP7148C	4	7.5A	1.5A	1.5A	1.5A				
EP7144C		4.5A	4.5A	1.5A	1.5A				
EP7145C		4.5A	3A	3A	1.5A				
EP7143C		3A	3A	3A	3A				
EP7010C	1	10A				1.8V	5 x 5 mm	25 mm ²	System Power & Chiplet Power
EP7027C	2	8A	2A						
EP7028C		6A	4A						
EP7029C		5A	5A						
EP7037C	3	6A	2A	2A					
EP7038C		4A	4A	2A					

ECAP - Silicon Capacitors

Part Number	# Capacitors	Capacitance	Max Operating Voltage	Package Size	Package + Pad Thickness
EC1004B	1	230nF	2.0V	0.64 x 0.5 mm	121 μm
EC2004B	2	460nF	2.0V	0.64 x 1.0 mm	125 μm
EC1007B	1	1.88μF	1.2V	1.12 x 0.98 mm	125 μm
EC2047B	17	4.8μF	2.0V	2.3 x 1.9 mm	200 μm
EC2027B	4	7.5μF	1.2V	2.26 x 1.98 mm	250μm
EC2005P	2	9.36μF	1.2V	2.00 x 2.00 mm	762 μm
EC2008P	2	11.9μF	1.2V	2.00 x 2.00 mm	762 μm
EC1005P	1	16.6μF	1.2V	3.66 x 3.05 mm	762 μm
EC2025P	4	18.72μF	1.2V	4.04 x 2.00 mm	762 μm
EC2006P	4	36.4μF	1.2V	4.00 x 4.00 mm	762 μm
EC2045P	8	37.44μF	1.2V	4.04 x 4.04 mm	762 μm

Empower Semiconductor provides **custom design services** for silicon capacitors, enabling optimized solutions that address specific electrical, physical, and mechanical specifications.

EMPOWER

SEMICONDUCTOR

USA/Global HQ

888 Tasman Drive
Suite 200
Milpitas, CA 95035
USA

T: +1 408 957 8750

China and Asia Pacific

Room B217,
Rongchao Binhai Building No.2021
Haixiu Road,
Bao'an District,
Shenzhen City, China



Representatives and Distributors

SEMIX
Engineering & Marketing LTD

dimacred
where reliability belongs

EDOM
TECHNOLOGY CO., LTD.



BoBhonestar
北高智

科宇盛达
KEYSIDA

世强硬创 世强硬创电商
www.sekorm.com

M **MOUSER**
ELECTRONICS

www.empowersemi.com